

To initiate warranty service, contact Laser Link Golf to obtain a RETURN AUTHORIZATION NUMBER (RAN). Write the RAN on the outside of the box and ship to the address below. **IMPORTANT:** Be sure to include a note explaining the reason for return and a proof of purchase. On the accompanying note, and on any other correspondence, be sure to include the model number, your name, return address, phone number, and email address.

Warranty returns will not be processed without this information.

Laser Link Golf
Attn: Repair Department
4027 Owl Creek Drive
Madison, WI 53718

THERE ARE NO OTHER EXPRESS WARRANTIES OTHER THAN THOSE STATED HEREIN. THIS WARRANTY GIVES YOU SPECIFIC LEGAL RIGHTS AND YOU MAY ALSO HAVE OTHER RIGHTS WHICH VARY FROM STATE TO STATE. ANY IMPLIED WARRANTIES, INCLUDING WARRANTIES OF MERCHANTABILITY AND FITNESS FOR A PARTICULAR PURPOSE, SHALL BE LIMITED IN DURATION TO THE PERIOD OF TIME SET FORTH ABOVE. LASER LINK GOLF SHALL NOT BE RESPONSIBLE FOR INCIDENTAL OR CONSEQUENTIAL DAMAGES. SOME STATES DO NOT ALLOW LIMITATIONS ON HOW LONG AN IMPLIED WARRANTY LASTS OR THE EXCLUSION OR LIMITATION OF INCIDENTAL OR CONSEQUENTIAL DAMAGES, SO THE ABOVE LIMITATIONS OR EXCLUSION MAY NOT APPLY TO YOU. LASER LINK GOLF NEITHER ASSUMES NOR AUTHORIZES ANYONE TO ASSUME FOR IT ANY OTHER EXPRESS WARRANTY.

THIS WARRANTY DOES NOT APPLY TO ANY ACCESSORIES NOR TO ANY PRODUCT SUBJECTED TO MISUSE, NEGLIGENCE OR ACCIDENTAL DAMAGE, IMPROPER SERVICE OR HANDLING, NOR TO ANY PRODUCTS ALTERED OR REPAIRED BY ANY PERSON OR COMPANY OTHER THAN LASER LINK GOLF.

The **Double Eagle DE** is sealed at the factory and cannot be opened. Any attempt to open the case will damage the unit and this damage will void the Limited Warranty.

Authorized Service Center:



4027 Owl Creek Drive • Madison, WI 53718 USA
Phone: (608) 838-3100 • **Toll Free:** 866-909-4653
www.laserlinkgolf.com

Does your golf course use our *SmartSticks*™?



MODEL 9507

Instruction Manual and Warranty Information

Simplifying your game!



Simplifying your game!

You have purchased the fastest, simplest, and easiest to use rangefinder in golf! The Double Eagle DE Rangefinder is designed specifically for those who enjoy playing the game of golf. It is so simple to operate that anyone from the newest beginner to the most experienced veteran, from a low handicapper to a high handicapper, can use it with ease. To learn more about the Double Eagle DE and the Laser Link Distance System, please read through the instruction manual.

Included in this package:

(1) Double Eagle DE Rangefinder (1) Carrying Case (1) Nine-Volt Battery

STARTING OUT

The Battery

Your new rangefinder comes equipped with a 9-volt alkaline battery already installed. It should be ready to use right out of the box.

When the battery runs low on power, a low battery indicator (🔋) will appear on the left side of the LCD screen. When replacing the battery, use only a 9-volt alkaline battery. DO NOT use heavy duty or lithium batteries.

OPERATING INSTRUCTIONS

The Double Eagle DE Rangefinder is a “target specific” laser rangefinder that will only read yardages from Laser Link Golf’s specially designed prism reflector. Because of this target specific design, the Double Eagle DE is so simple to use that you will be an expert the first time you try it. You will always get the reading to the flagstick (not the reading to the trees behind the green), even if your hands are not perfectly steady. The minimum range is 30 yards; the maximum range is 300 yards.

BATTERY INSTALLATION

To install a new battery, slide the battery door on the bottom of the handle to the open position. When installing the new battery, do so with the receptors facing up, and with the positive receptor (the smaller of the two receptors at the top of the battery) positioned closer to the front of the rangefinder.

Use only a 9-volt alkaline battery for replacement.

One button does it all...

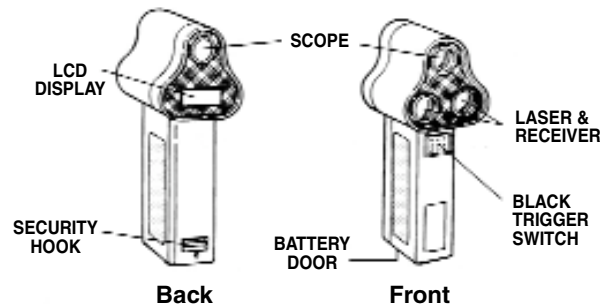

To Use:

1. Hold the Double Eagle DE with the LCD screen facing you.
2. Bring the hand-held unit up to your eye. Aim the scope in the direction of your target.
3. **PRESS AND RELEASE** the green button located under your trigger finger. A red dot aiming reference will appear in the top scope. When the red dot is present, the laser is firing. Flashing “dashes” will also appear on the LCD screen indicating that the laser is firing. If the word “On” appears on the LCD, simply press and release the button again and the “dashes” will appear. The laser will transmit for 10 seconds.
4. **Align the red dot just above the top of the flagstick, and slowly trace the red dot in an “up and down” motion along the full length of the flagstick.** The reflector will either be on top of the flagstick, or directly below the flag. The unit will read a yardage when the laser hits the target reflector. There is no need to be perfectly steady, simply get close. DO NOT press the green button again and DO NOT hold down the button; simply press and release once, and scan the red dot along the target flagstick.
5. The unit will beep twice when your yardage has been calculated. Yardage measurement will be displayed for 6 seconds.

**NOTE: The red dot in the scope is simply an aiming reference, not the actual laser. By tracing the red dot down the length of the flagstick – you will then get familiar with the mechanism and be able to use the unit with ease.*

OPERATION NOTES

- **Rapid Fire** – The Double Eagle DE Rangefinder has the capability for “rapid fire” use. You do not need to wait for a previous yardage measurement to clear the LCD screen prior to using again.
- **Auto Shutoff** – The Double Eagle DE Rangefinder has an automatic shutoff function that will automatically turn off the unit after approximately 6 seconds
- **Weather Conditions** – Rain will affect performance only if the unit gets water on the inside, or if the rain is falling intensely enough so that it completely covers the reflector at all times.

Fog can have an effect on performance. The thicker the fog, the higher the chance for limited ranging capabilities.

Do not expose the rangefinder to extreme heat or extreme cold for long periods of time. Everyday use and travel are acceptable, and will not affect the rangefinder itself. However, long-term storage in extreme temperatures can have an effect on the rangefinder, battery performance, and/or battery life.

- **Water Resistance** – The Double Eagle DE casing is water resistant. However, DO NOT submerge the rangefinder in water.

MAINTENANCE

- To clean the lenses and LCD screen, use a soft, clean cloth, such as you would use on eyeglasses. Both the lenses and the LCD can be scratched, so DO NOT use a hard-bristled brush. DO NOT use liquid of any type to clean these areas.
- It is recommended that the rangefinder be stored in its carrying case when not in use.

TROUBLESHOOTING

Issues that you encounter with any of our Laser Link rangefinders are often easily solved without returning the unit to Laser Link Golf. In many cases, **the remedy can be as simple as changing the battery**, and we recommend that this be done prior to returning the product to Laser Link Golf.

The rangefinder is reading an incorrect yardage.

- Replace the battery. Check to see if the low battery indicator (🔋) is present on the LCD screen. If there is not enough power being supplied to the rangefinder, yardage measurements may be compromised.

The rangefinder gets a reading only some of the time.

- First, make sure the reflector is clean and free of any obstructions, including dirt, mud, or excessive calcium or salt buildup. Also make sure nothing is blocking the sending or receiving lenses of the rangefinder, such as your finger.
- In many cases, a slight change in user behavior that will make the unit work perfectly, and using the “Operating Instructions” procedure outlined earlier will often solve the problem. If you continue to have difficulties getting readings, please contact Laser Link Golf for help.

SPECIFICATIONS

Product: Double Eagle DE

Model: 9507

Dimensions: 5 5/8" x 2 3/16" x 3"

Weight (with battery): 6.5 ounces

Class One Laser

Power Source: 9 Volt Battery
(alkaline only)

Range: 30 – 300 yards
(27 – 274 meters)

Accuracy: +/- 1%

Display: LCD

Carrying case included

ONE-YEAR LIMITED WARRANTY

LASER LINK GOLF warrants to the original consumer purchaser thereof all parts of the **Double Eagle DE Rangefinder** to be free from defects in materials or factory workmanship for a period of one (1) year from the date of original purchase by the consumer. **LASER LINK GOLF** will, at its option, replace or repair this product or any part thereof, except batteries, if it proves to be defective under normal use and service within one (1) year from date of original purchase.